

Item	Qty.	Description
1	1	41.25" Round Vertical Extrusion w/Door Hinges
2	2	41.25" Vertical Extrusion
3	2	41.25" Vertical Extrusion w/Standoffs
4	1	41.25" Vertical Extrusion w/Door Hinges
5	1	41.25" Vertical Extrusion w/Door Stops
6	4	18" Z45 Horizontal Extrusion
7	6	23" Curved Horizontal Extrusion
8	4	31.12" Curved Horizontal Extrusion

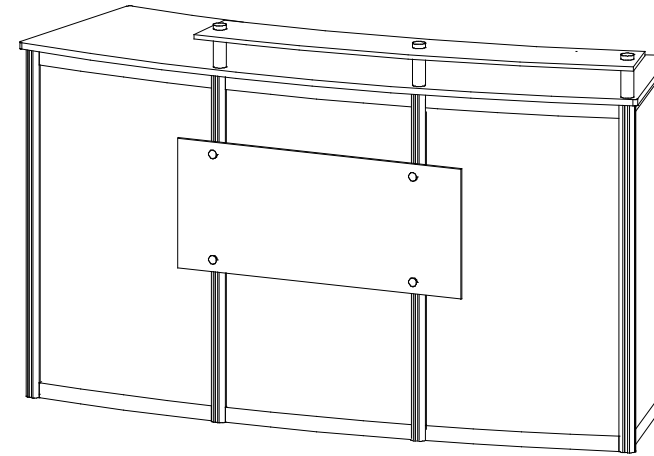

**Steps:**

- 1) Connect lower horizontal extrusions between vertical extrusions where indicated.
- 2) Insert infills panels and attach doors where indication.
- 3) Attach upper horizontal extrusions between vertical extrusions.
- 4) Attach graphic to front of counter using standoffs as shown.
- 5) Attach upper shelf to counter top using standoffs as shown.
- 6) Place counter top atop assembled base.

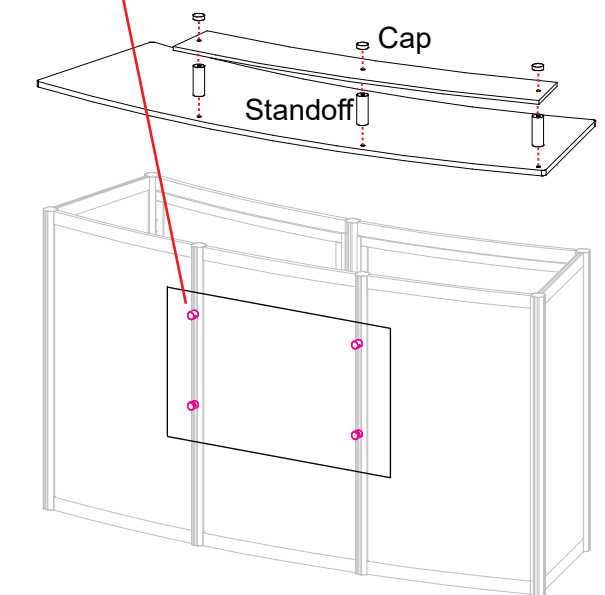
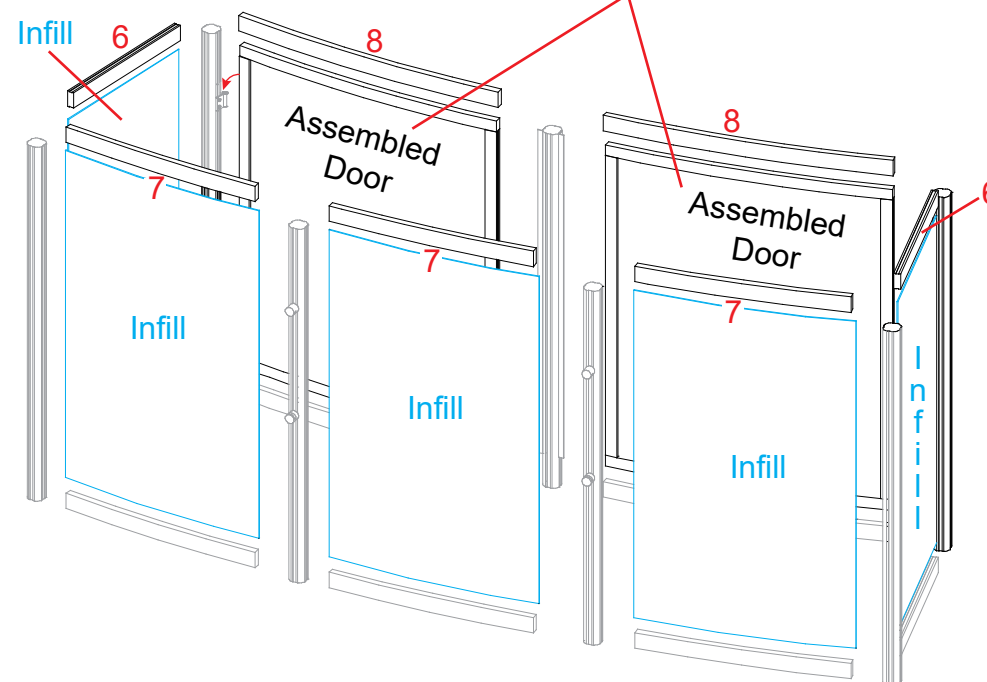
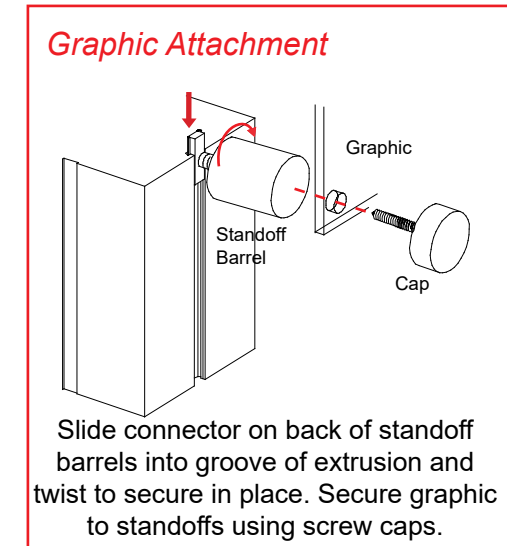
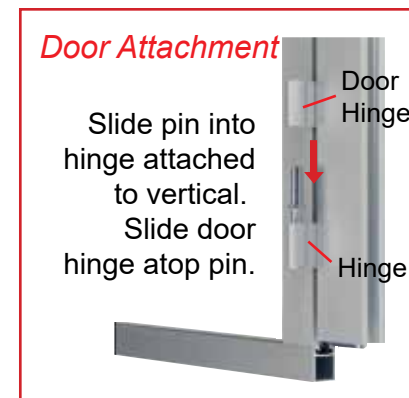
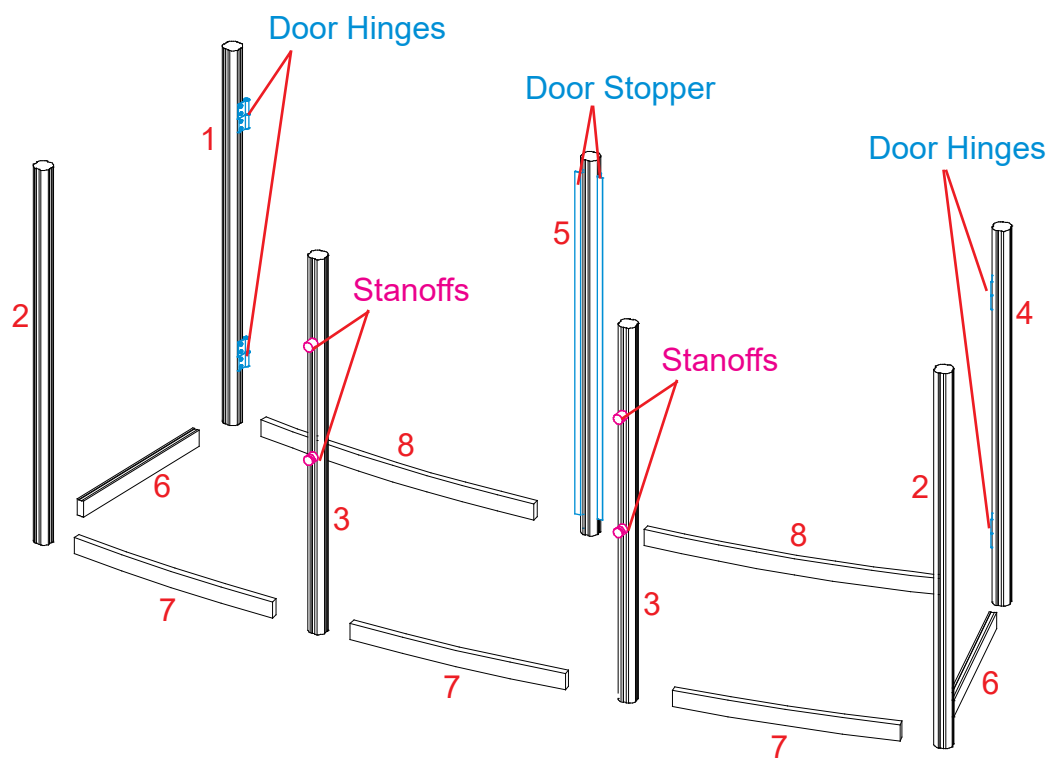

# SETUP INSTRUCTIONS

## General Setup Instructions

- Read entire setup instruction manual prior to unpacking parts and pieces.
- The setup instructions are created specifically for this configuration.
- Setup instructions are laid out sequentially in steps, including exploded views with detailed explanation for assembly.

## Cleaning & Packing

- For Cleaning Metal, Plex, & Laminate Parts: Use a **MILD NON-ABRASIVE** cleanser and soft cloth/paper towel to clean all surfaces.
- Keep exhibit components away from heat and prolonged sun exposure. **Heat and UV exposure will warp and fade components.**
- Retain all provided Packing Materials. All provided packing materials are for ease of repacking & component protection.

## Disassembly

- For loss prevention, tighten all set screws and locks during disassembly.

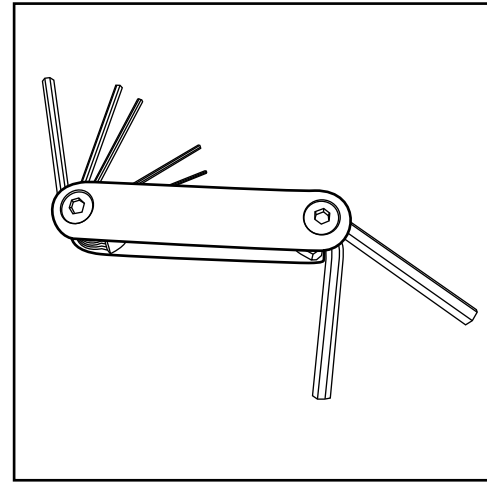

Hex Tool - Essential for Assembly

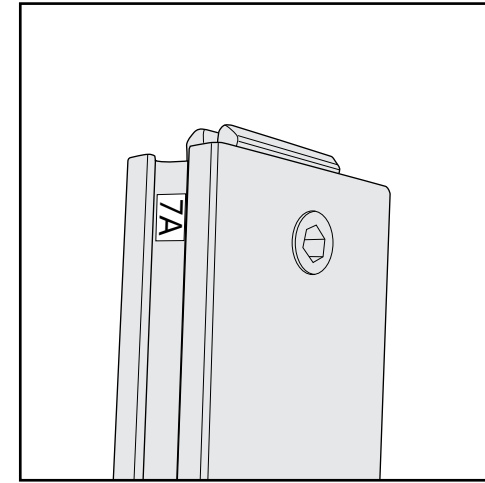

Part Identification - Numbering

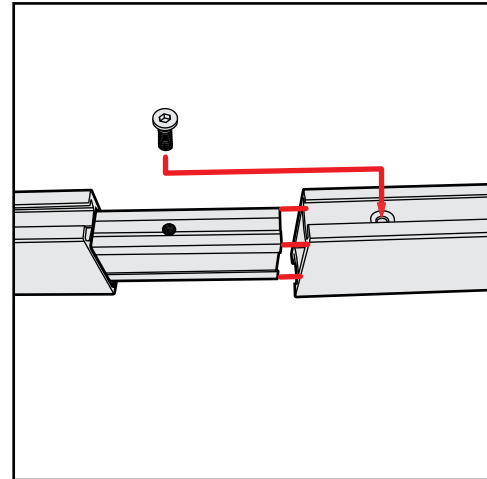

Spline Connection

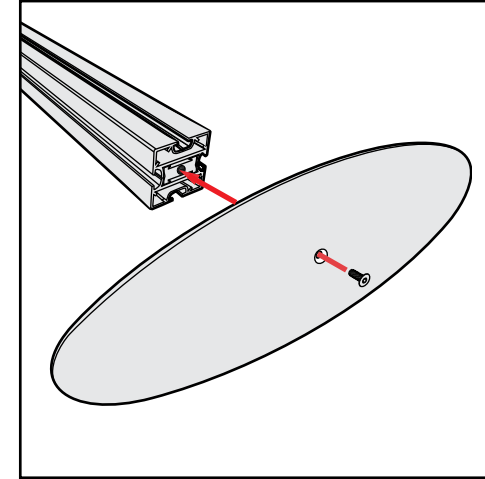

Base Plate & Extrusion Connection

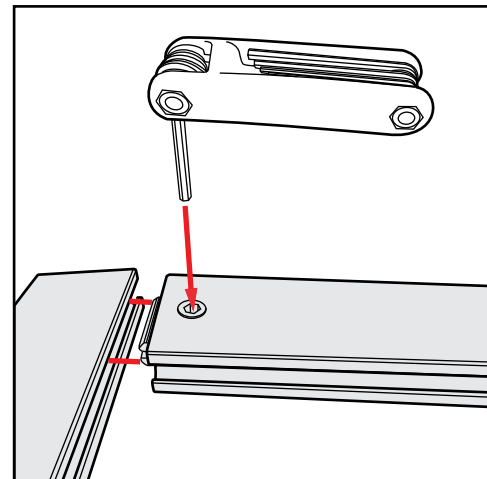

Extrusion & Lock Connection

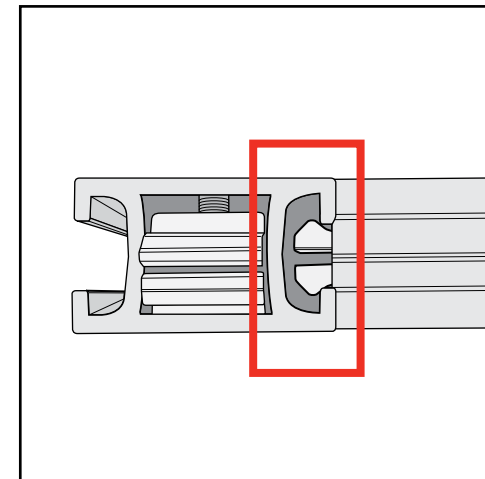

Engaged Lock



**WARNING**



DO NOT USE POWER TOOLS

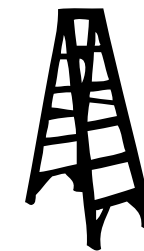

LADDERS OR LIFTS  
MAY BE REQUIRED



ALL CONNECTIONS MUST  
BE TIGHTLY SECURED