

Item	Qty.	Description:
1	1	40" Q918 Vertical Extrusion
2	1	40" Q918 Vertical Extrusion
3	1	40" S44 Vertical Extrusion
4	1	40" Q918 Vertical Extrusion
5a/5b	1/1	19.25" Curved Horizontal Extrusion
6a/6b	1/1	8" Horizontal Extrusion
7a/7b	1/1	19.25" Curved Horizontal Extrusion

- Steps:**
- 1) Attach lower horizontal extrusions [5,6,7] between vertical extrusions [1-4] as shown.
  - 2) Slide infills into place between verticals as shown except **clear infills**.  
Note: Slide **clear infills** into place after three **clear shelves** are installed.
  - 3) Attach upper horizontal extrusions [5,6,7] between vertical extrusions [1-4] as shown.
  - 4) Place **shelves** on pins as shown.
  - 5) Slide **clear infills** into place after three **clear shelves** are installed.
  - 6) Attach stand-off barrels to curved extrusions [5,7].
  - 7) Place clear plex counter top on barrels and secure with screw caps.

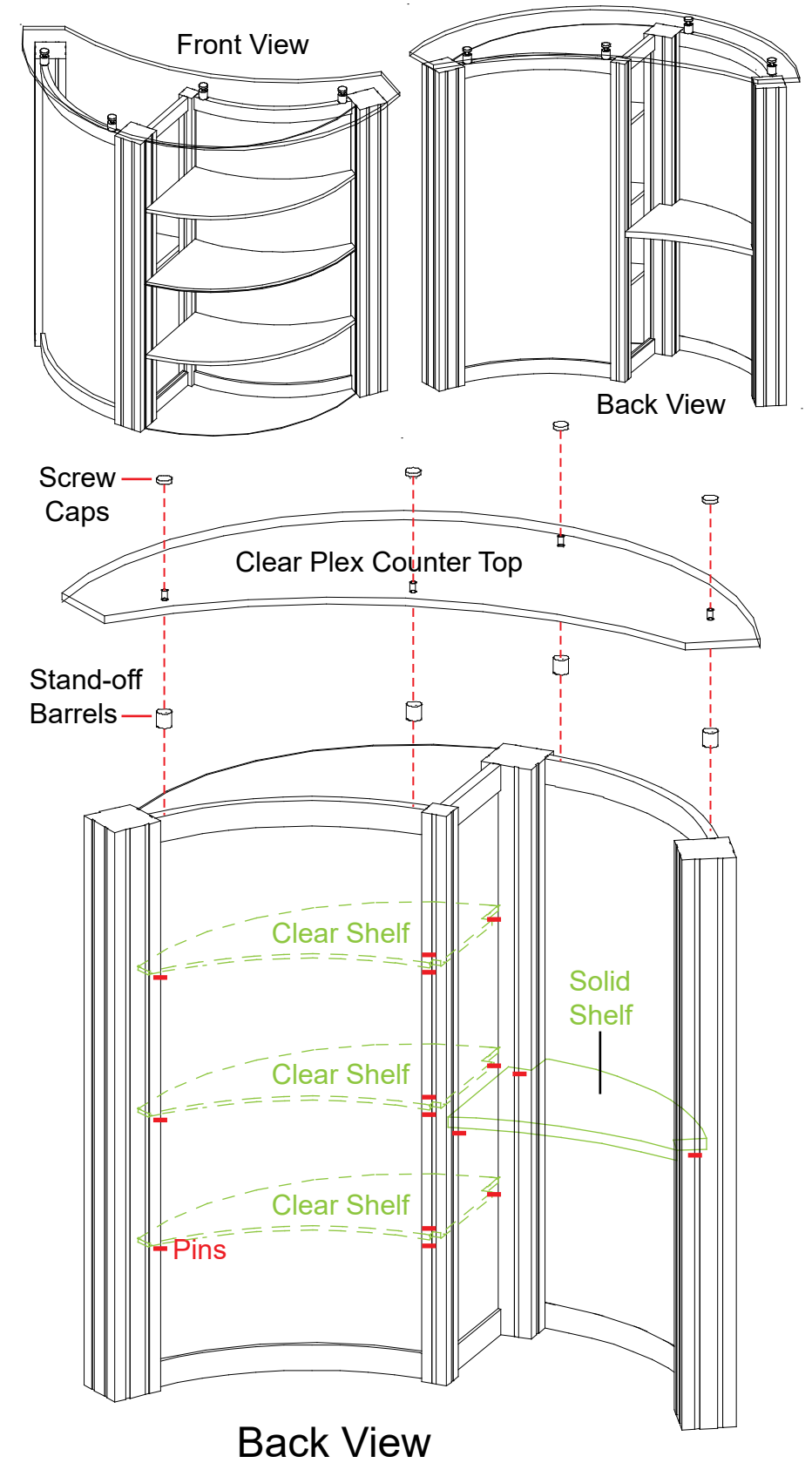
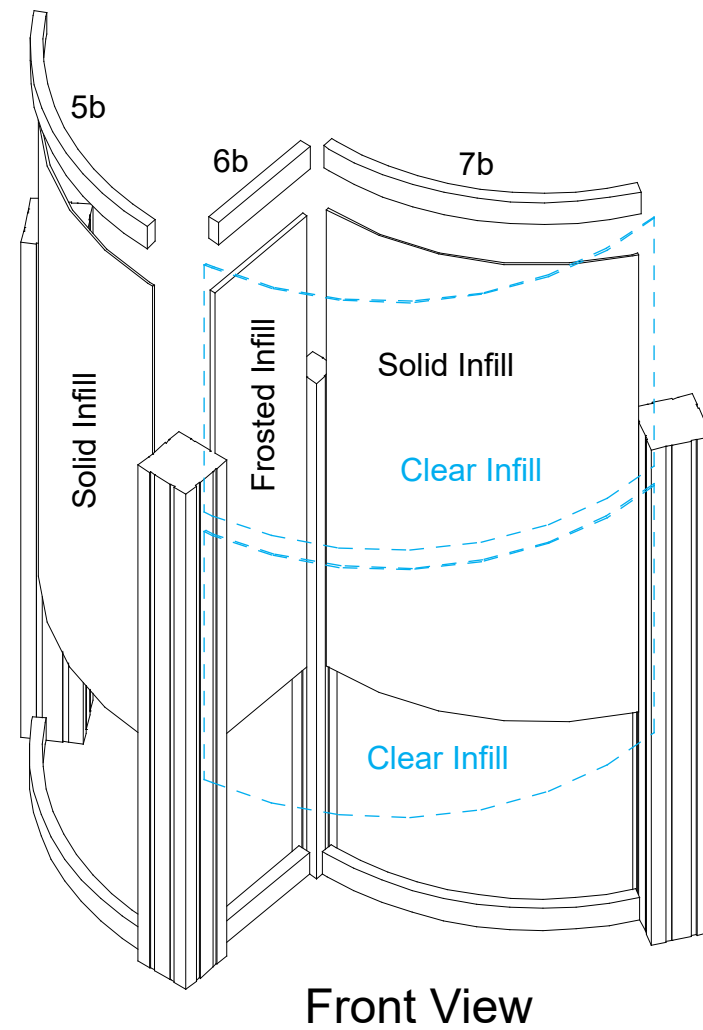
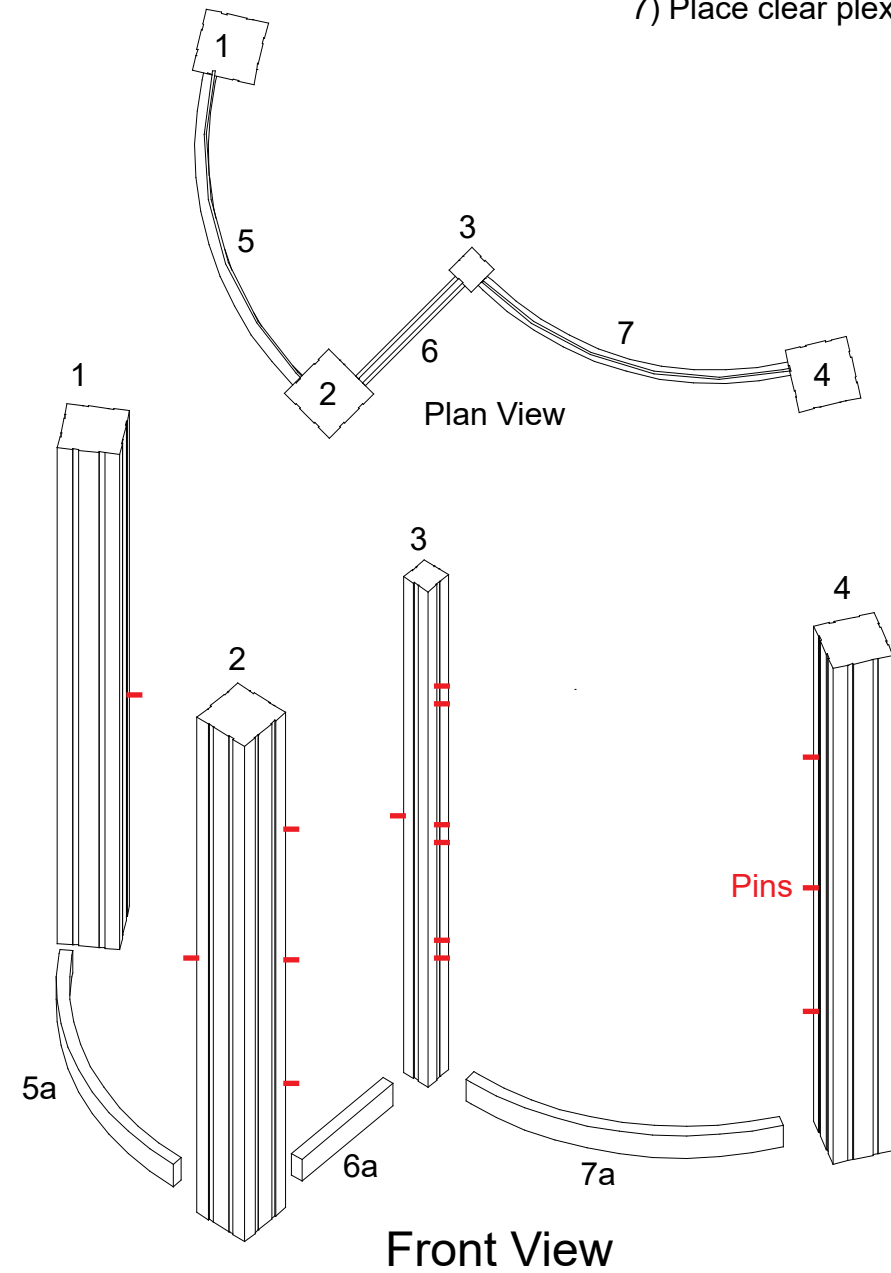

# SETUP INSTRUCTIONS

## General Setup Instructions

- Read entire setup instruction manual prior to unpacking parts and pieces.
- The setup instructions are created specifically for this configuration.
- Setup instructions are laid out sequentially in steps, including exploded views with detailed explanation for assembly.

## Cleaning & Packing

- For Cleaning Metal, Plex, & Laminate Parts: Use a **MILD NON-ABRASIVE** cleanser and soft cloth/paper towel to clean all surfaces.
- Keep exhibit components away from heat and prolonged sun exposure. **Heat and UV exposure will warp and fade components.**
- Retain all provided Packing Materials. All provided packing materials are for ease of repacking & component protection.

## Disassembly

- For loss prevention, tighten all set screws and locks during disassembly.

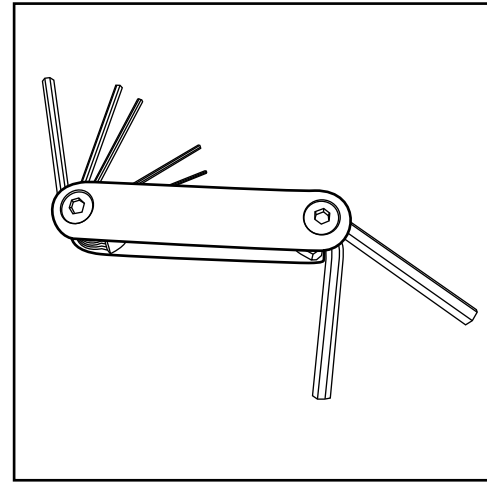

Hex Tool - Essential for Assembly

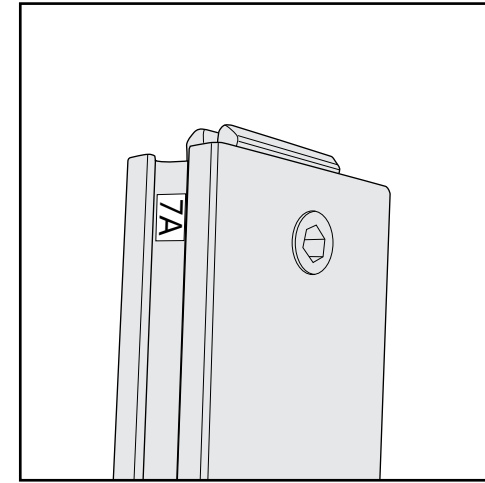

Part Identification - Numbering

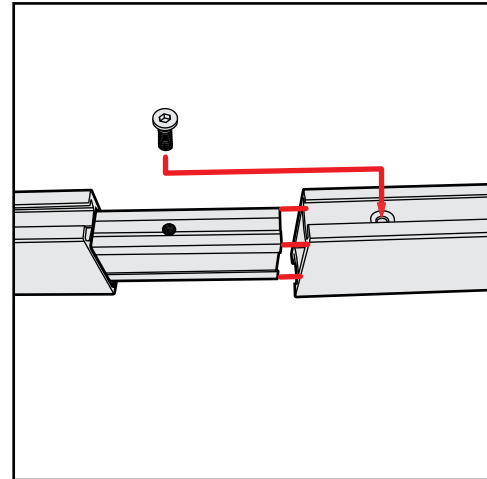

Spline Connection

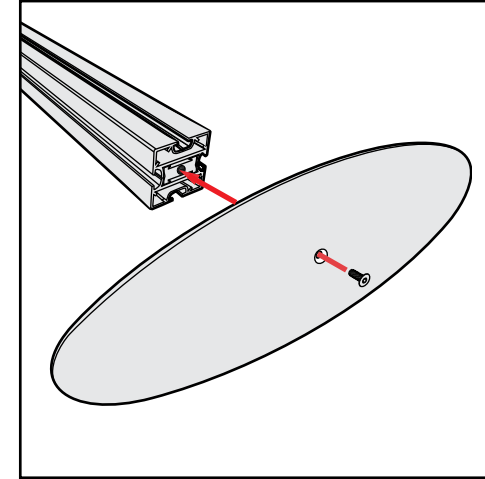

Base Plate & Extrusion Connection

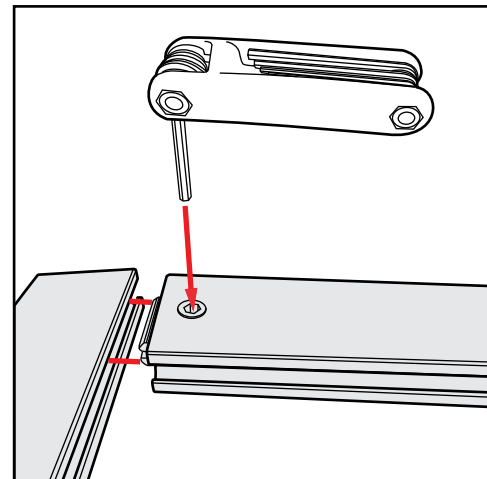

Extrusion & Lock Connection

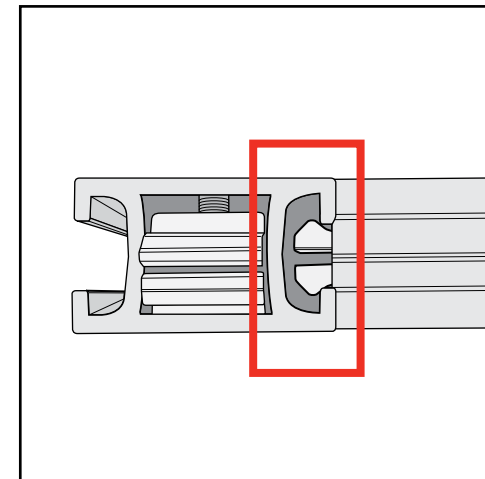

Engaged Lock



# WARNING

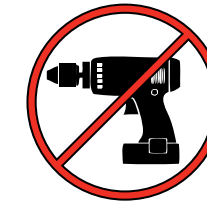

DO NOT USE POWER TOOLS

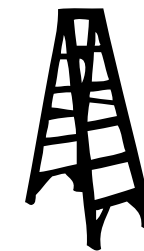

LADDERS OR LIFTS  
MAY BE REQUIRED



ALL CONNECTIONS MUST  
BE TIGHTLY SECURED

**Top View Case 1**

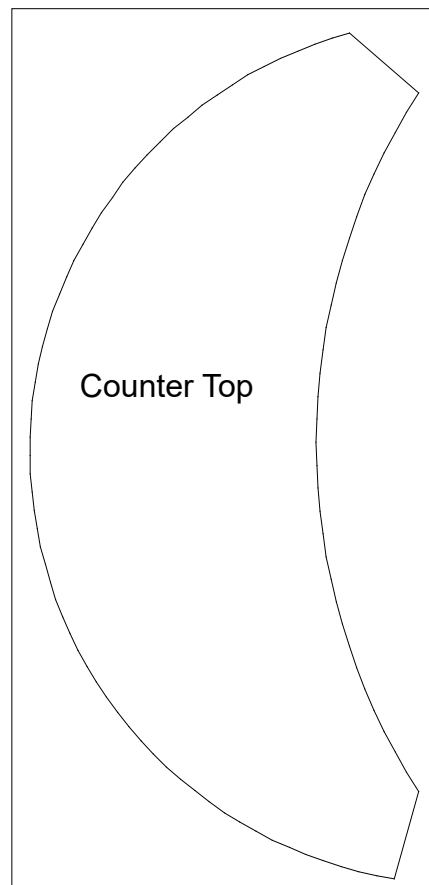

Level 1

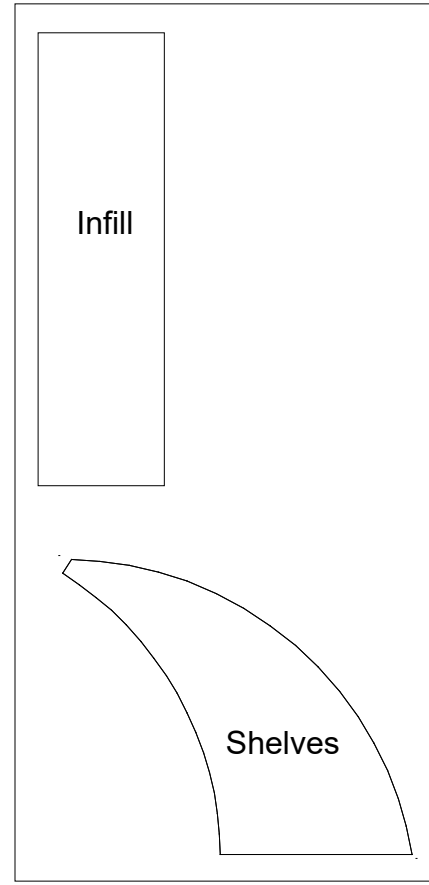

Level 2

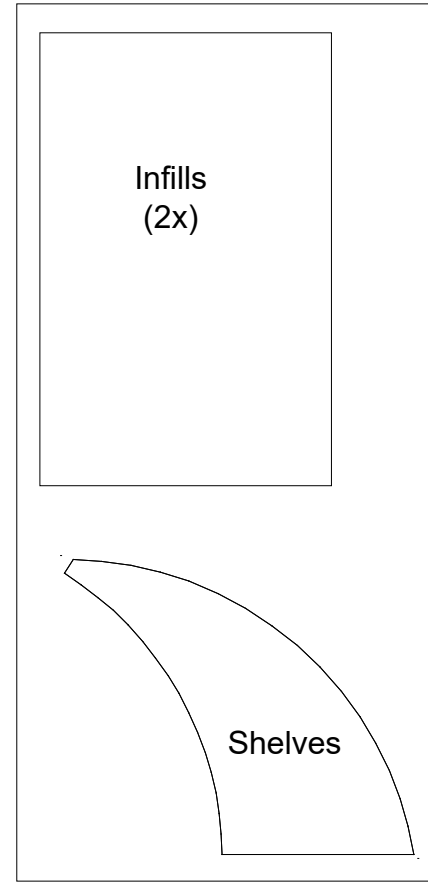

Level 3

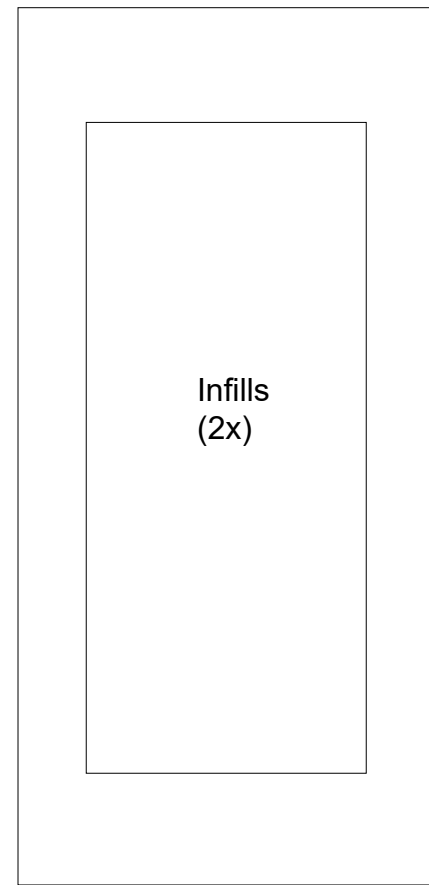

Level 4

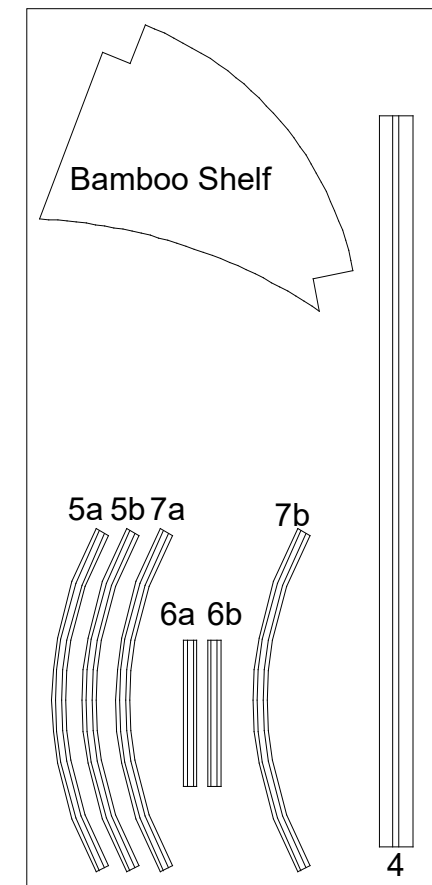

Level 5

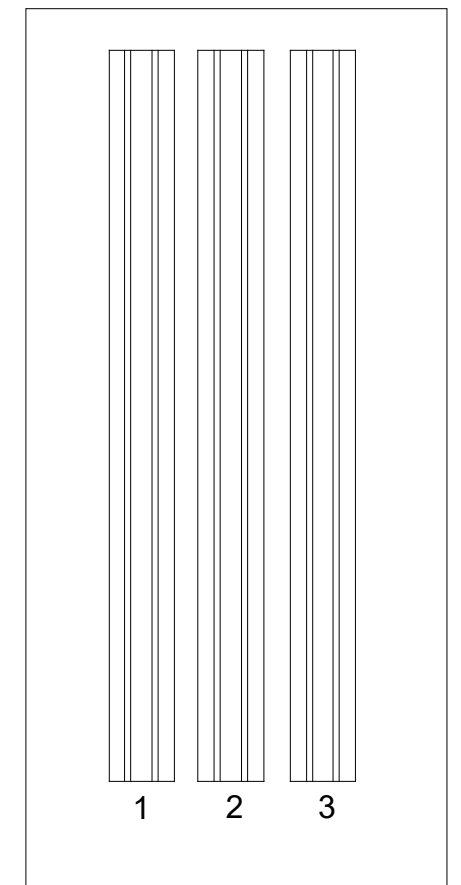

Level 6